

**2012**

**INDIANA PINTO**

**SPRING SHOW**

**PATTERN BOOK**

NOTE: This Pattern Book offered for your connivence. It is the exhibitors responsibility to check the official posted patterns prior to showing for any last minute corrections.

Revised April 17, 2012\_JG

**IPtHA 2012 SPRING SHOW  
SHOWMANSHIP - ENGLISH & WESTERN  
NOVICE AMATEUR & NOVICE YA & YA W/T WESTERN  
CLASS 18, 19, 20**

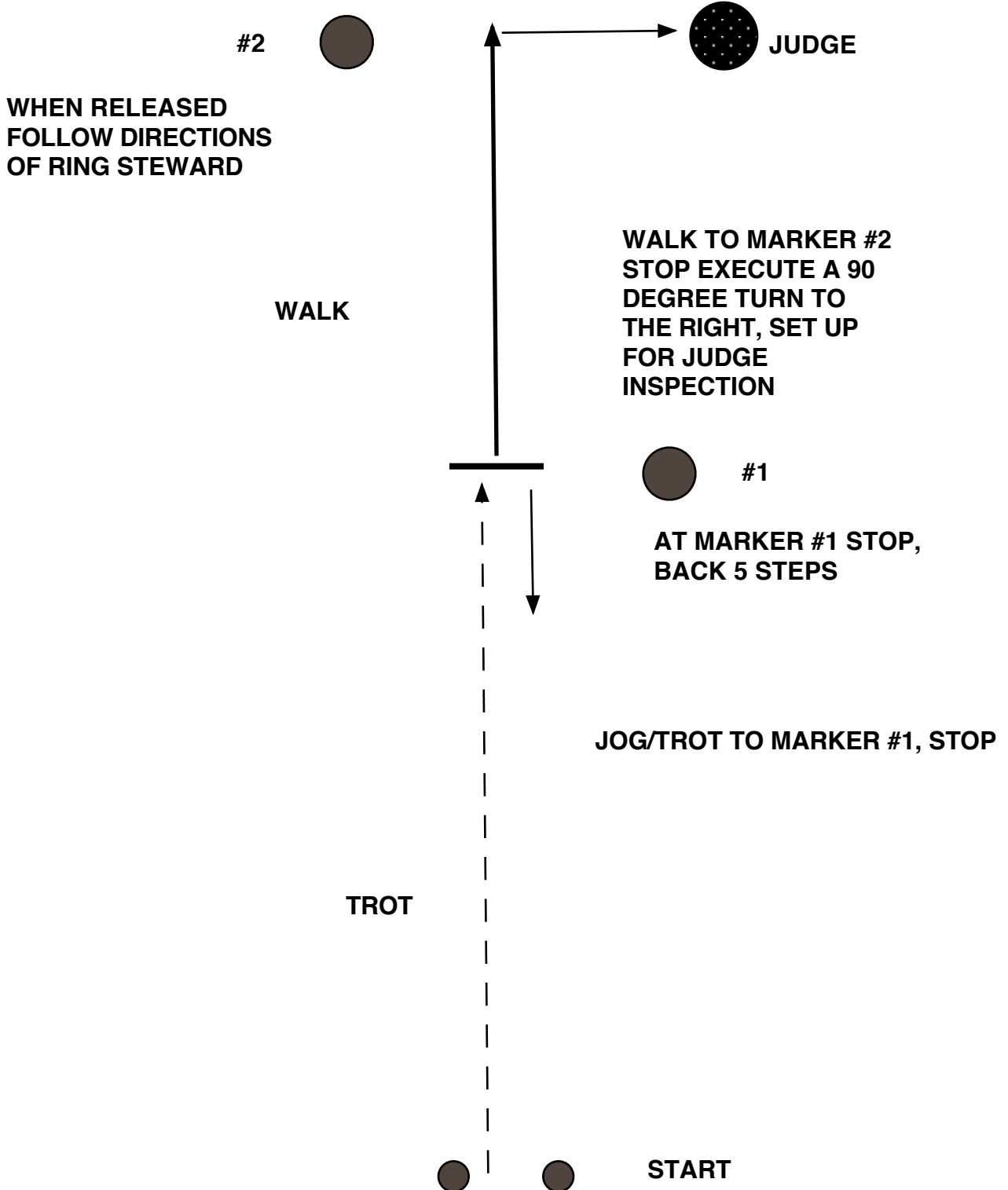

# IPTHA 2012 SPRING SHOW AM/YA SHOWMANSHIP WESTERN CLASSES 21,22,23,24,25

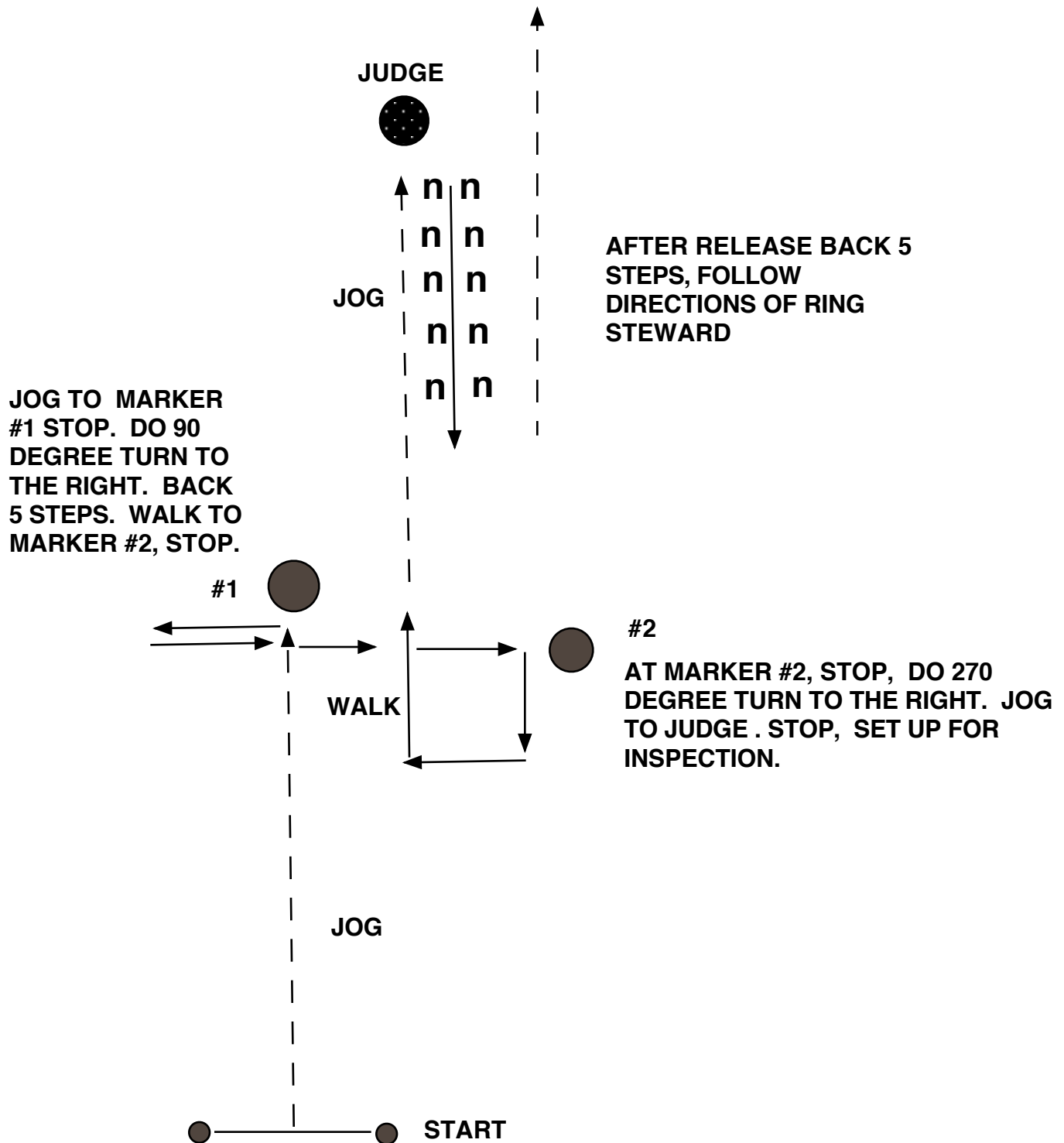

**2012 INDIANA PINTO SPRING SHOW  
SHOWMANSHIP - ENGLISH  
YOUTH & AMATEUR  
CLASSES 30,31,32,33**

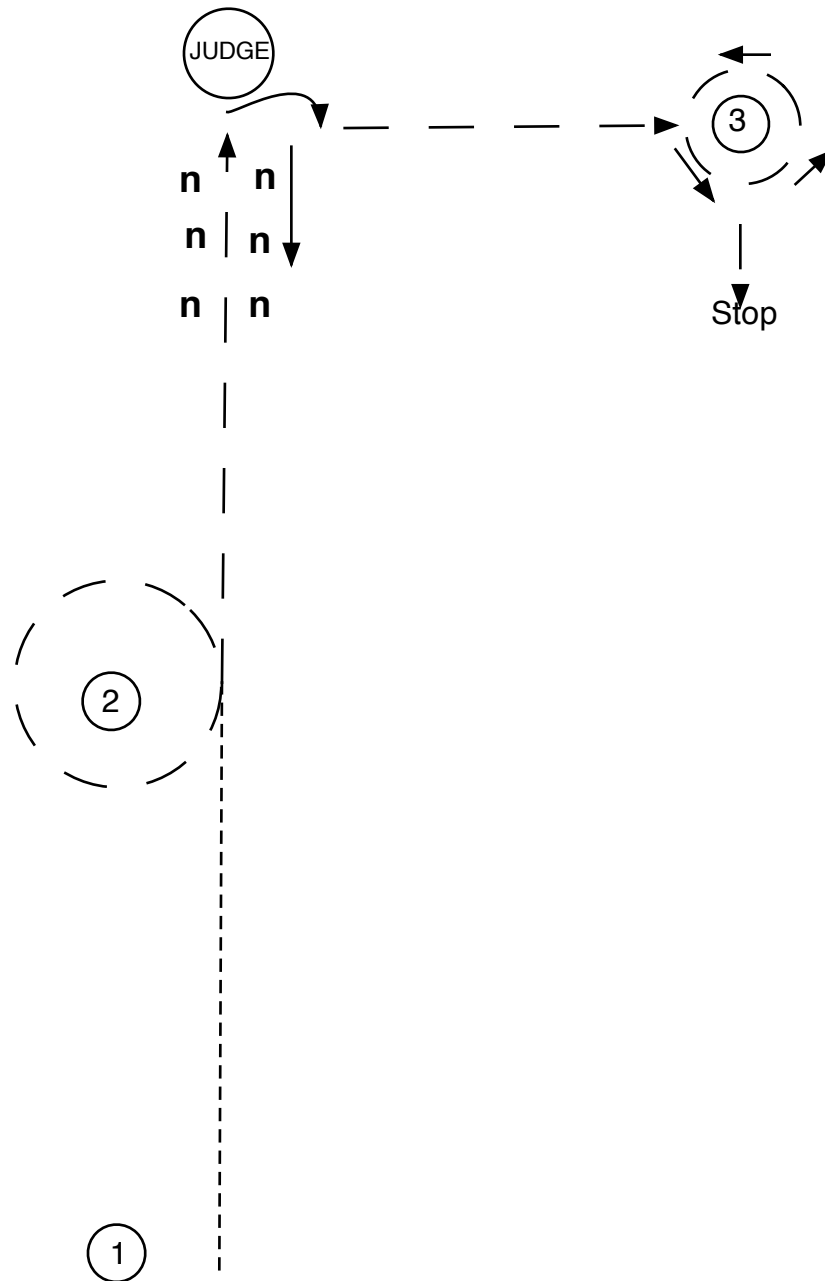

1. Be ready at cone #1.
2. Walk to cone #2.
3. At cone #2 trot a circle around #2 and continue to trot to the Judge.
4. Stop and set up for inspection.
5. Back 3 steps
6. Do a 90 degree turn to the right, trot to and around cone #3 and stop.
7. End of pattern, follow Ring Steward's instructions.

**IPtHA 2012 SPRING SHOW  
SHOWMANSHIP - ENGLISH  
YOUTH WALK/TROT  
CLASS 34**

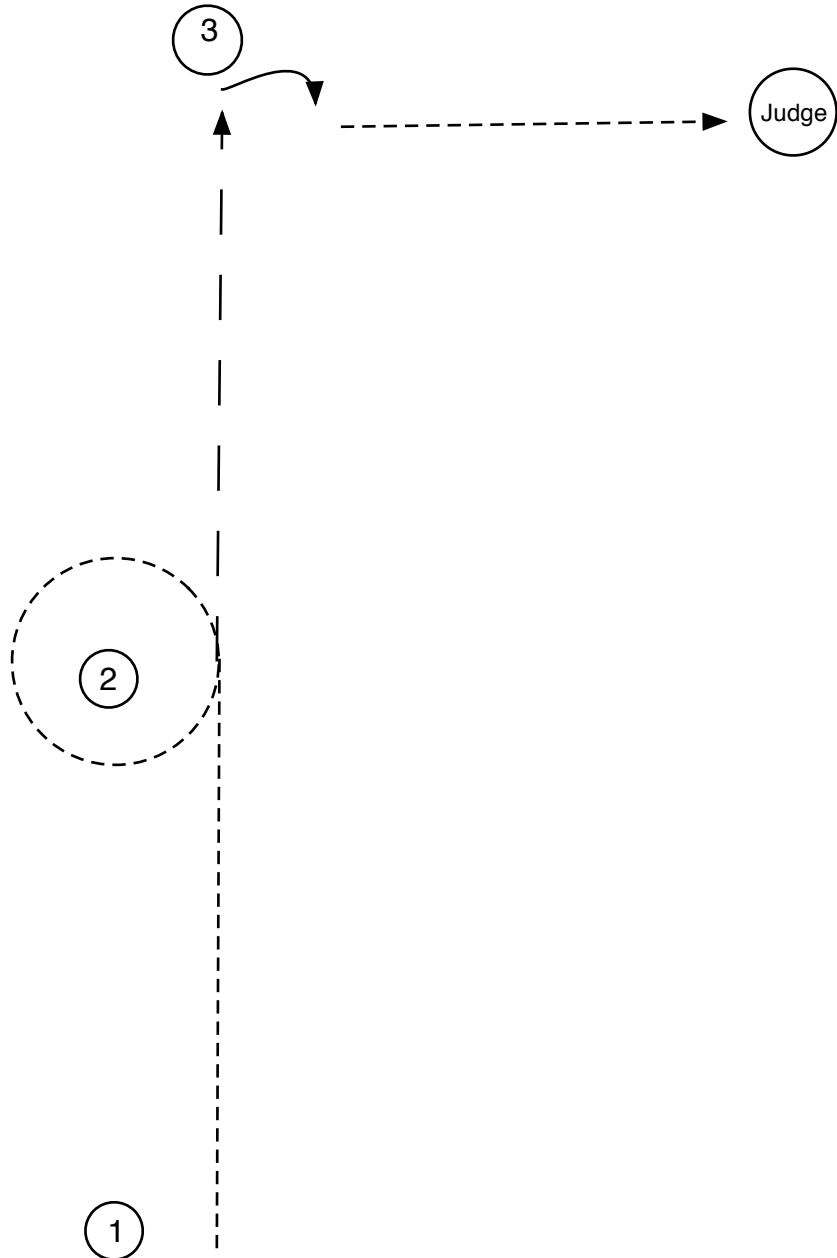

1. Be ready at cone #1.
2. Walk to and around cone #2.
3. Trot to cone #3, stop.
4. Do a 90 degree turn, walk to Judge and stop.
5. Set up for inspection
6. When released by Judge follow Ring Steward's instructions.

**2012 INDIANA PINTO SPRING SHOW  
ENGLISH EQUITATION  
YOUTH & AMATEUR  
CLASSES 50,51,52**

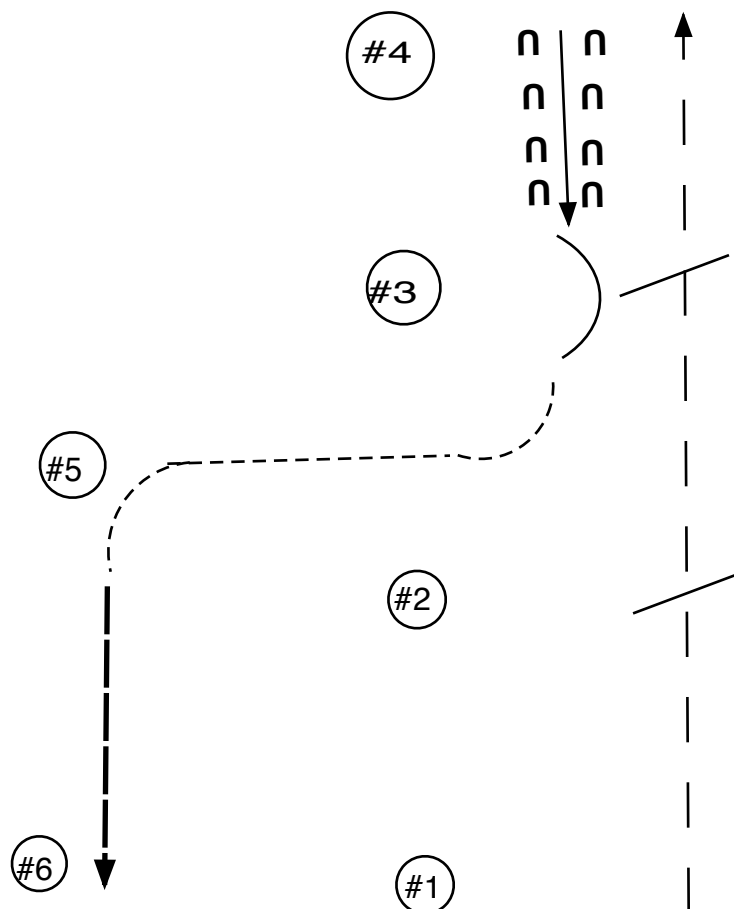

1. Trot from cone #1 to Cone #4 starting on the right diagonal and changing diagonals at #2 and #3
2. Stop at cone #4, back 4 steps.
3. Execute a 180 degree turn on the forehand, either direction
4. Walk curve past cone #3 toward cone #5
5. At cone #5 pick up canter on right lead to exit, pattern ends at #6

**IPtHA 2012 SPRING SHOW  
EQUITATION ENGLISH  
YOUTH & AMATEUR  
NOVICE & BAREBACK  
CLASSES 53,54,55,56**

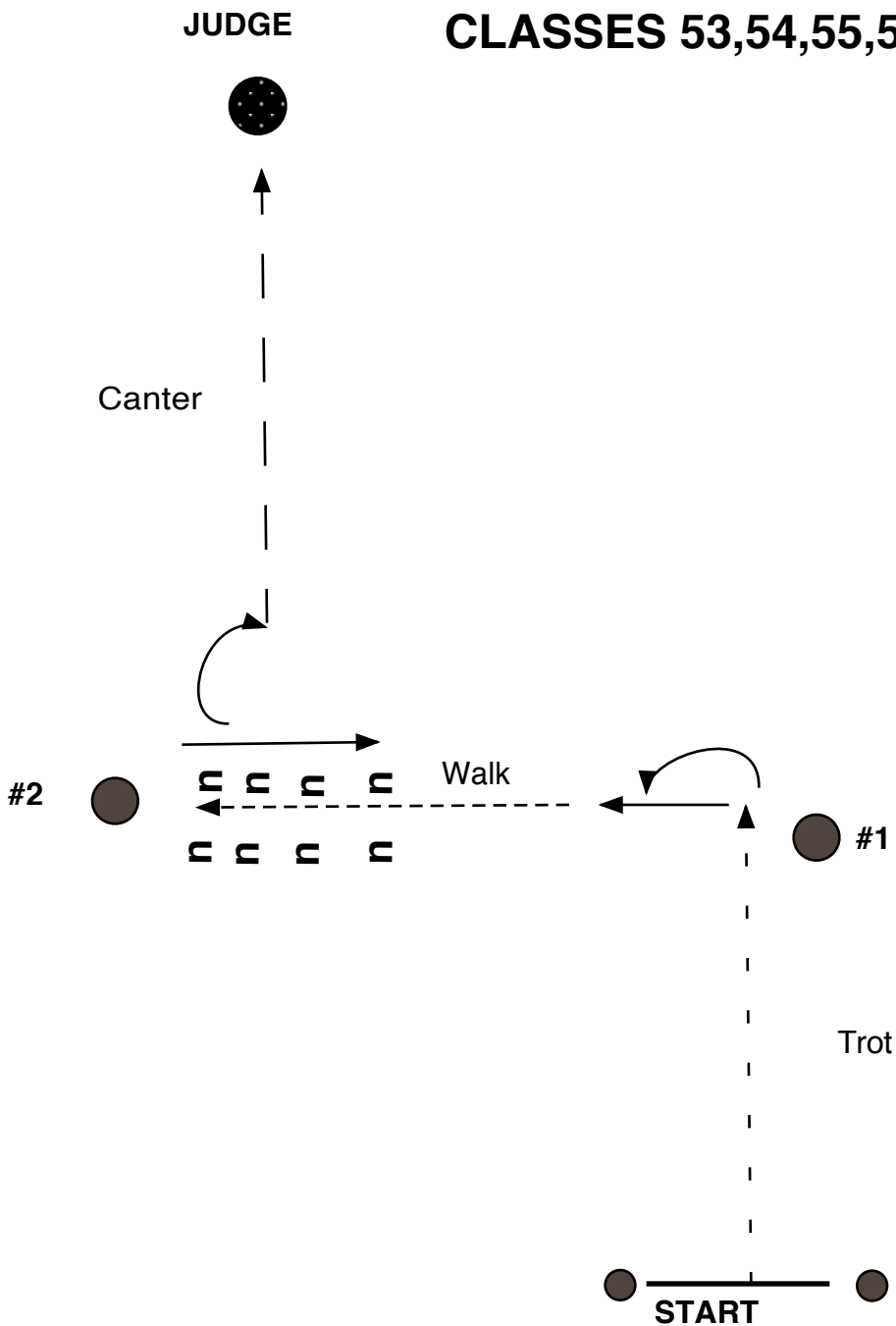

1. Trot from start to cone #1, stop.
2. At cone #1 execute a 90 degree turn to the left.
3. Walk to cone # 2, stop back 3 steps, execute a 90 degree turn to the right.
4. Canter to Judge on Left Lead and set up for inspection.
5. When released follow Ring Steward's instructions.



2012 IPtHA SPRING SHOW  
REINSMANSHIP  
A71 Y72

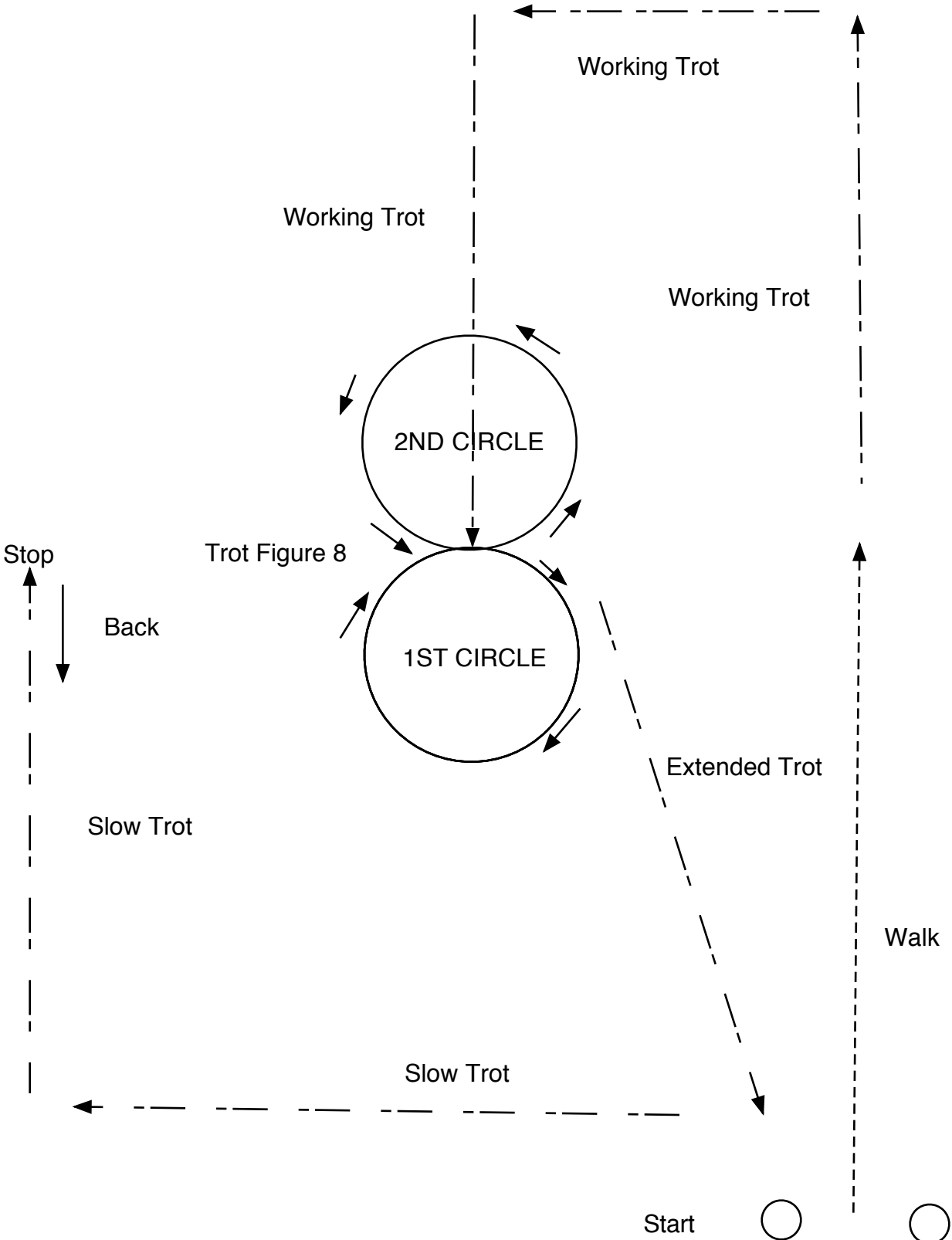

2012 INDIANA PINTO SPRING SHOW  
MINIATURE HUNTER-INHAND  
CLASS 77

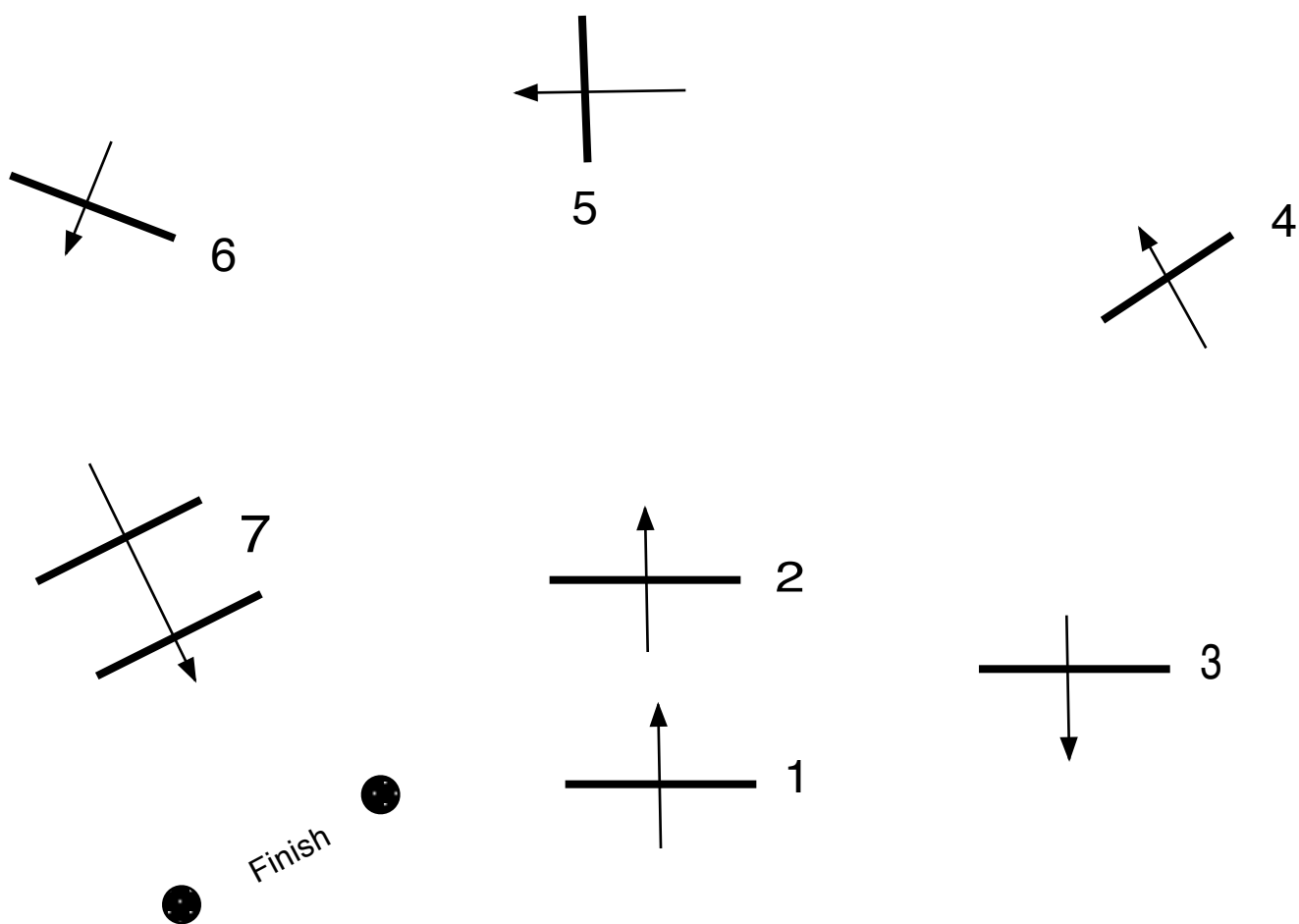

● Start ●

# 2012 IPtHA SPRING SHOW SHOW

## JUMPING IN HAND

P78 M79 Y-P/M80 A-P/M81

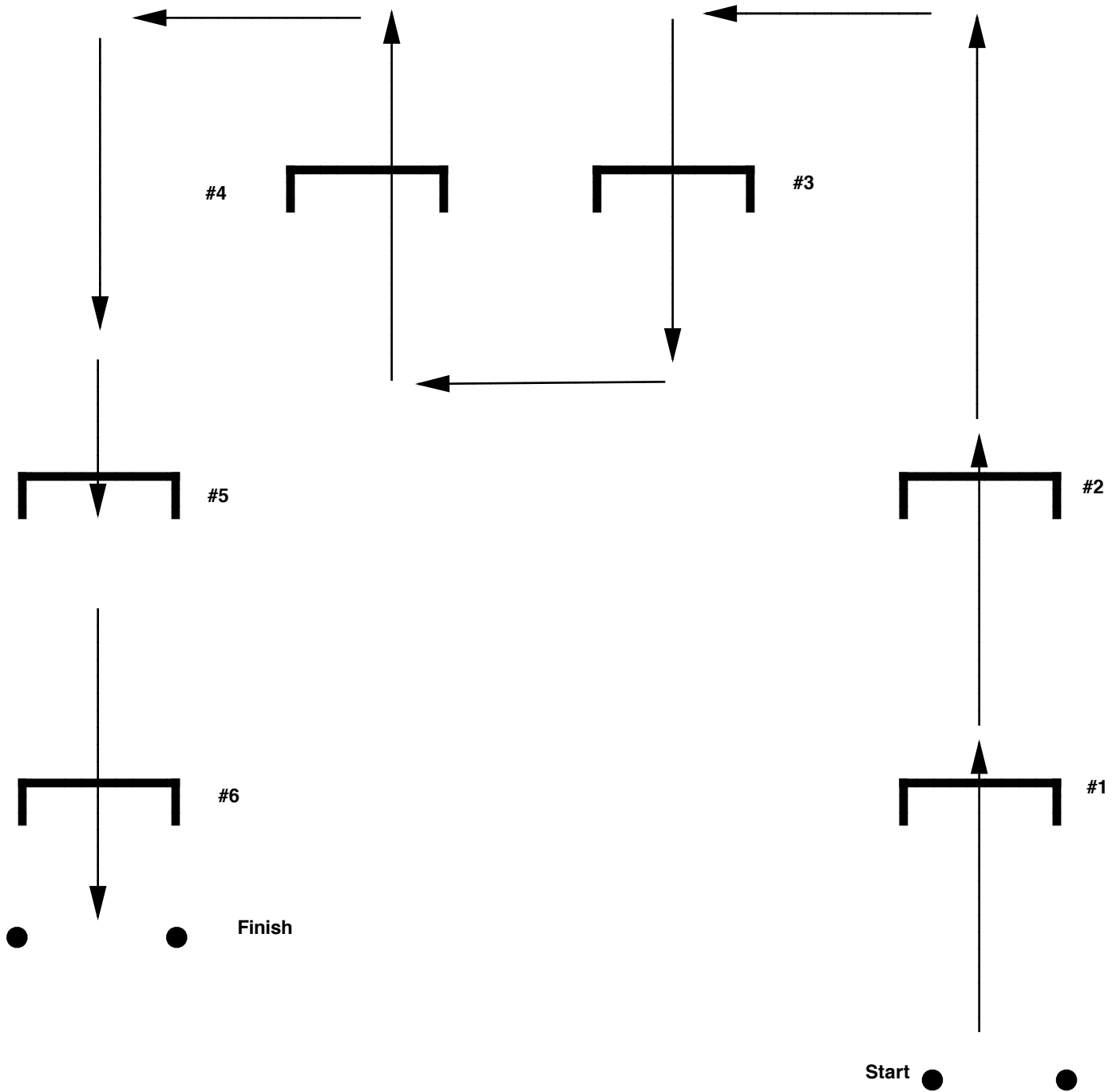





**IPtHA 2012 SPRING SHOW  
AM NOVICE WALK/TROT, YA WALK/TROT & ADULT WALK/TROT  
EQUITATION ENGLISH & WESTERN  
CLASSES 102,103,104**

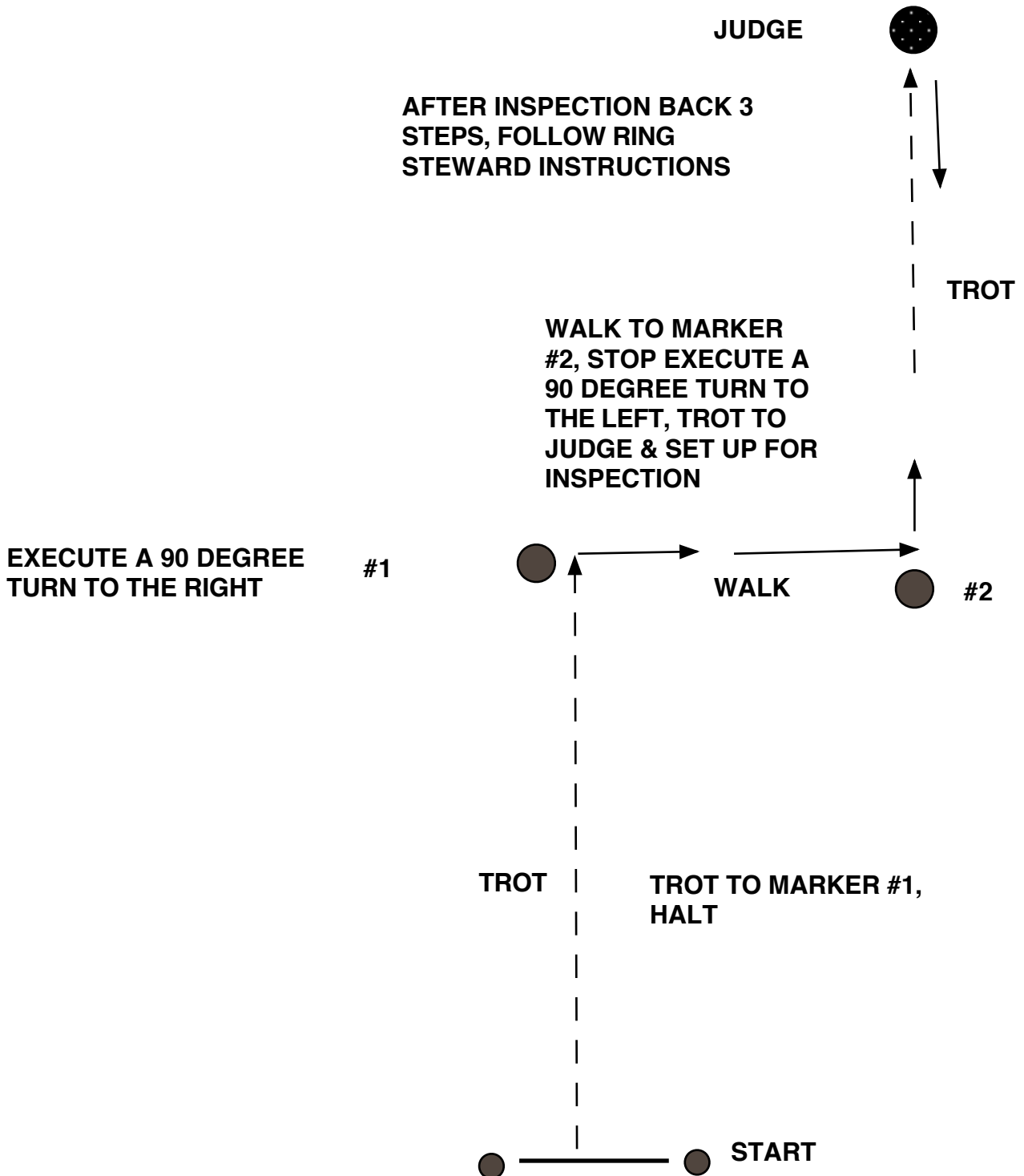

**2012 INDIANA PINTO SPRING SHOW  
HORSEMANSHIP - WESTERN  
YA and AMATEUR  
CLASSES 117,118,119,120,121**

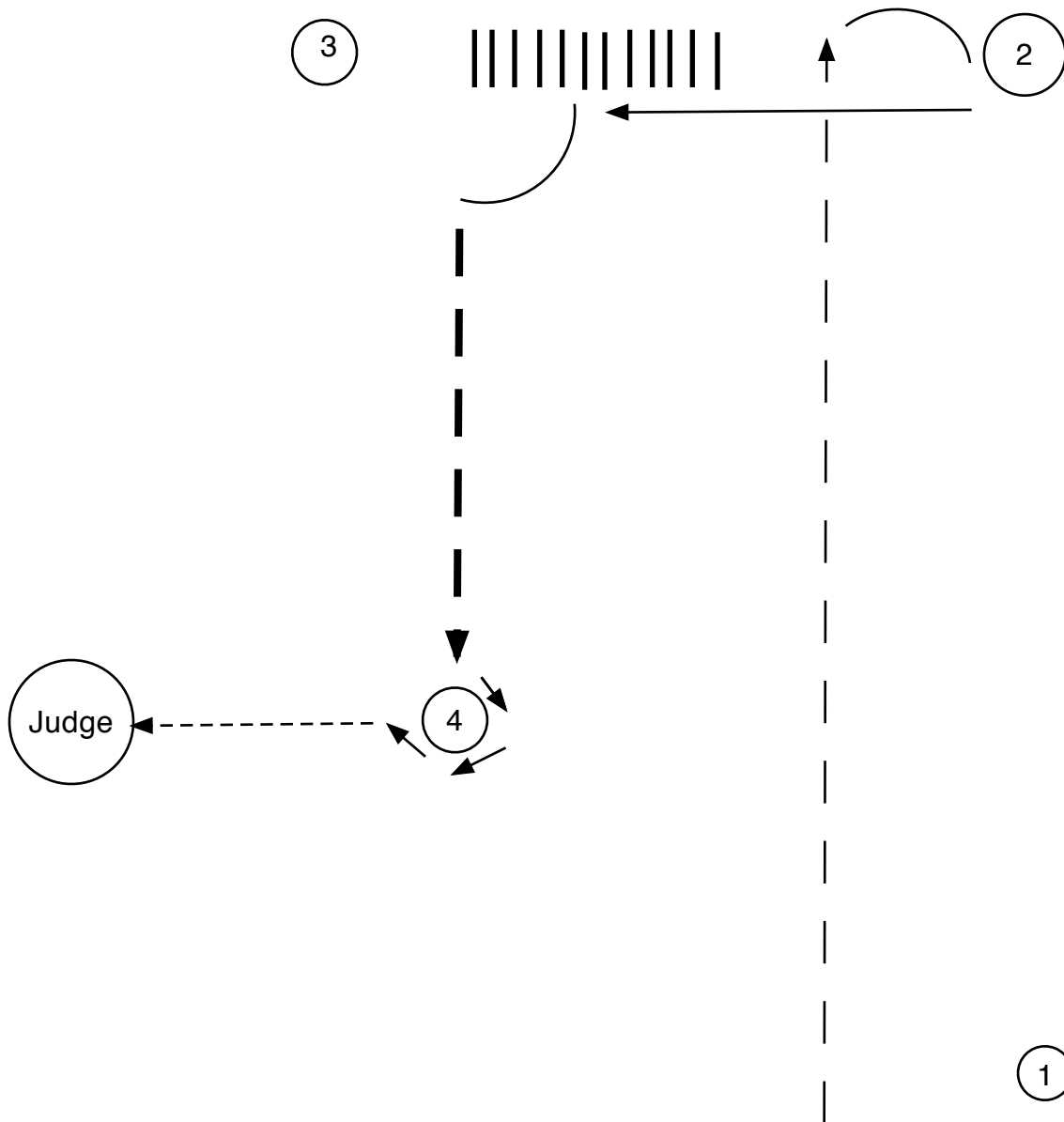

1. Start at cone #1.
2. Jog until even with cone 2, stop execute 90 Degree Turn
3. Back to cone #3
4. Execute a 90 degree turn, Lope to and 3/4 way around cone 4
5. Break to a walk
6. Walk to Judge, Set up for Inspection, exit when dissimised by Judge